

Ranges Available

<Standard specifications> (Temp at 0% input = 0°C)

K	Specify between 0-100°C and 0-1350°C in steps of 50°C (e.g. K 0 to 350°C).
E	Specify between 0-100°C and 0-1000°C in steps of 50°C (e.g. E 0 to 150°C).
J	Specify between 0-100°C and 0-800°C in steps of 50°C (e.g. J 0 to 550°C).
T	Specify between 0-100°C and 0-400°C in steps of 50°C (e.g. T 0 to 250°C).
B	Specify between 0-1200°C and 0-1800°C in steps of 100°C (e.g. B 0 to 1700°C).
R	Specify between 0-400°C and 0-1700°C in steps of 100°C (e.g. R 0 to 1400°C).

<Quasi-standard specifications>

Type	Temperature Range (°C)	(+) Bias	(-) Bias
K	-200 to +1370	Up to 5x input span.	Up to 1x input span.
E	-200 to +1000	Up to 3x input span.	Up to 0.5x input span.
J	-200 to +1200	Up to 5x input span.	Up to 0.5x input span.
T	-200 to +400	Up to 2x input span.	Up to 0.5x input span.
B	0 to +1820	Up to 5x input span.	N/A
R	-50 to +1760	Up to 10x input span.	No limitation.
S	-50 to +1760	Up to 10x input span.	No limitation.
N	-200 to +1300	Up to 5x input span.	Up to 0.5x input span.

Input Spec Ex. 1: For K -100 to 400°C, the input span is 500°C and the bias -0.2x the input span.

Input Spec Ex. 2: For J 300 to 400°C, the input span is 100°C and the bias 3x the input span.

Note 1: Input span: 3mV min.

Note 2: For input temperature ranges starting from any specified temperature below 0°C, the accuracy may be partly out of specification.

Note 3: For the type B thermocouple, the accuracy in the temperature range below 600°C is not guaranteed.

Note 4: Any specification out of the temperature range or bias requirement listed above is handled as a special order.

OUTPUT SECTION

Allowable Output Load

Voltage Output (DC)	1V span and up	2mA max.
	10mV	10kΩ min.
	100mV	100kΩ min.
Current Output (DC)	4 to 20mA	750Ω max.

Zero Adjustment Approx. ±5% of span. (Adjustable by the front-accessible trimmer.)

Span Adjustment Approx. ±5% of span. (Adjustable by the front-accessible trimmer.)

Burnout Protection Standard: Upscale (Downscale is optional.)

Ranges Available

	Current Signal	Voltage Signal
Output Range (DC)	0 to 20mA	-10 to 10V
Output Span (DC)	4 to 20mA	10mV to 20V
Output Bias	0 to 100%	-100 to 100%

* For current output signals, the accuracy of any current output smaller than 0.1mA is not guaranteed.

Output Spec Ex. 1: For 4 to 20mA output, the output span is 16mA and the bias +25%.

Output Spec Ex. 2: For -1 to 4V output, the output span is 5V and the bias -20%.

PERFORMANCE

Accuracy Rating

Better than ± [0.1% of span + 0.5°C {Cold junction compensation error} + Linearity error] (at 25°C±5°C)

Note: Linearity errors vary with input spans.

Input Span	Linearity Error (%)	Input Span	Linearity Error (%)
JIS K 0-300°C	0.1	JIS K 0-600°C	0.15
JIS J 0-200°C	0.15	JIS E 0-200°C	0.15
JIS E 0-600°C	0.25	JIS R 0-1600°C	0.5
JIS S 0-1000°C	0.25	JIS T 0-300°C	0.25

Temperature Effect Better than ±0.2% of span per 10°C change in ambient.

Response Time 160ms max. (0 to 90%) with a step input at 100%.

CMRR 100dB min. (500V AC, 50/60Hz)

Isolation 3-way isolation between input, output, and power.

Insulation Resistance 100MΩ min. (@ 500V DC) between input, output, and power.

Dielectric Strength Input / Output / Power: 2000V AC for 1 minute (Cutoff current: 0.5mA)

Surge Withstand Capability Tested as per ANSI/IEEE C37.90.1-1989.

Operating Environment Ambient temperature: -5 to 55°C Humidity: 5 to 90% RH (non-condensing)

Storage Temperature -10 to 60°C

PHYSICAL

Installation Wall/DIN rail mounting

Mounting Direction Vertical

Screwing Torque 0.78 to 1.18 [Nm] * Recommended

Wiring M3.5 screw terminal connection

External Dimensions W51 × H85 × D136.5 mm

Weight Main unit: 200g max.

Socket: 60g max.

MATERIAL

Housing ABS resin (UL 94V-0)

Socket ABS resin (UL 94V-0)

Screw Terminal Galvanized steel with trivalent chromate finish

Printed Circuit Board Glass fabric, epoxy resin (FR-4: UL 94V-0)

TERMINAL ASSIGNMENTS

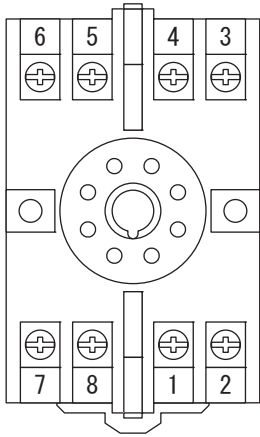

①	+ OUTPUT
②	- OUTPUT
③	T.C. +
④	T.C. -
⑤	N.C.
⑥	N.C.
⑦	P (+)
⑧	N (-)

POWER

BLOCK DIAGRAM

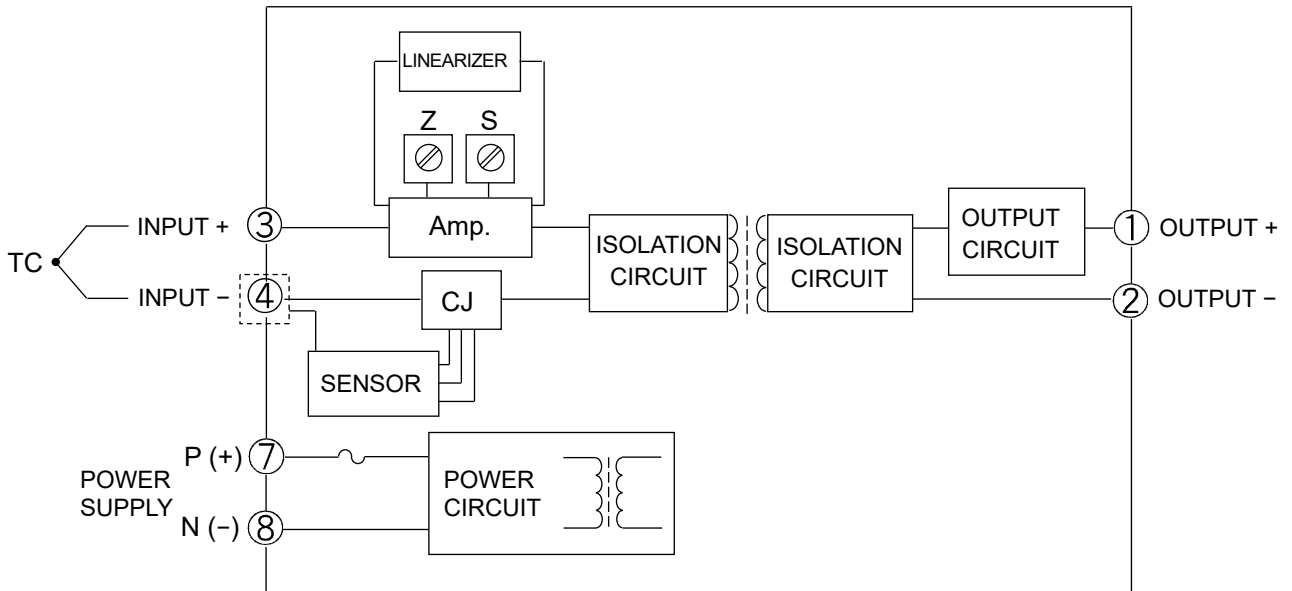

Zero Adjustment	Approx. $\pm 5\%$ of span. (Adjustable by the front-accessible trimmer.)	
Span Adjustment	Approx. $\pm 5\%$ of span. (Adjustable by the front-accessible trimmer.)	
Burnout Protection	Upscale (even if any of the three wires, A, B, and B' is opened)	
Ranges Available	Current Signal	Voltage Signal
Output Range (DC)	0 to 20mA	-10 to 10V
Output Span (DC)	4 to 20mA	10mV to 20V
Output Bias	0 to 100%	-100 to 100%

* For current output signals, the accuracy of any current output smaller than 0.1mA is not guaranteed.

Output Spec Ex. 1: For 4 to 20mA output, the output span is 16mA and the bias +25%.

Output Spec Ex. 2: For -1 to 4V output, the output span is 5V and the bias -20%.

PERFORMANCE

Accuracy Rating	Better than $\pm 0.15\%$ of span (at $25^{\circ}\text{C} \pm 5^{\circ}\text{C}$).
Temperature Effect	Better than $\pm 0.2\%$ of span per 10°C change in ambient.
Response Time	170ms max. (0 to 90%) with a step input at 100%.
CMRR	100dB min. (500V AC, 50/60Hz)
Isolation	3-way isolation between input, output, and power.
Insulation Resistance	100M Ω min. (@ 500V DC) between input, output, and power.
Dielectric Strength	Input / Output / Power: 2000V AC for 1 minute (Cutoff current: 0.5mA)
Surge Withstand Capability	Tested as per ANSI/IEEE C37.90.1-1989.
Operating Environment	Ambient temperature: -5 to 55°C Humidity: 5 to 90% RH (non-condensing)
Storage Temperature	-10 to 60°C

PHYSICAL

Installation	Wall/DIN rail mounting
Mounting Direction	Vertical
Screwing Torque	0.78 to 1.18 [Nm] * Recommended
Wiring	M3.5 screw terminal connection
External Dimensions	W51 x H85 x D136.5 mm (including the socket)
Weight	Main unit: 200g max. Socket: 60g max.

MATERIAL

Housing	ABS resin (UL 94V-0)
Socket	ABS resin (UL 94V-0)
Screw Terminal	Galvanized steel with trivalent chromate finish
Printed Circuit Board	Glass fabric, epoxy resin (FR-4: UL 94V-0)

TERMINAL ASSIGNMENTS

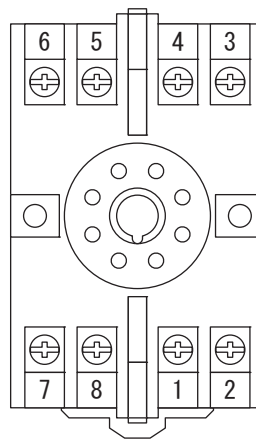

①	+ OUTPUT	
②	- OUTPUT	
③	RTD A	
④	RTD B	
⑤	RTD B'	
⑥	N.C.	
⑦	P (+)	POWER
⑧	N (-)	

BLOCK DIAGRAM

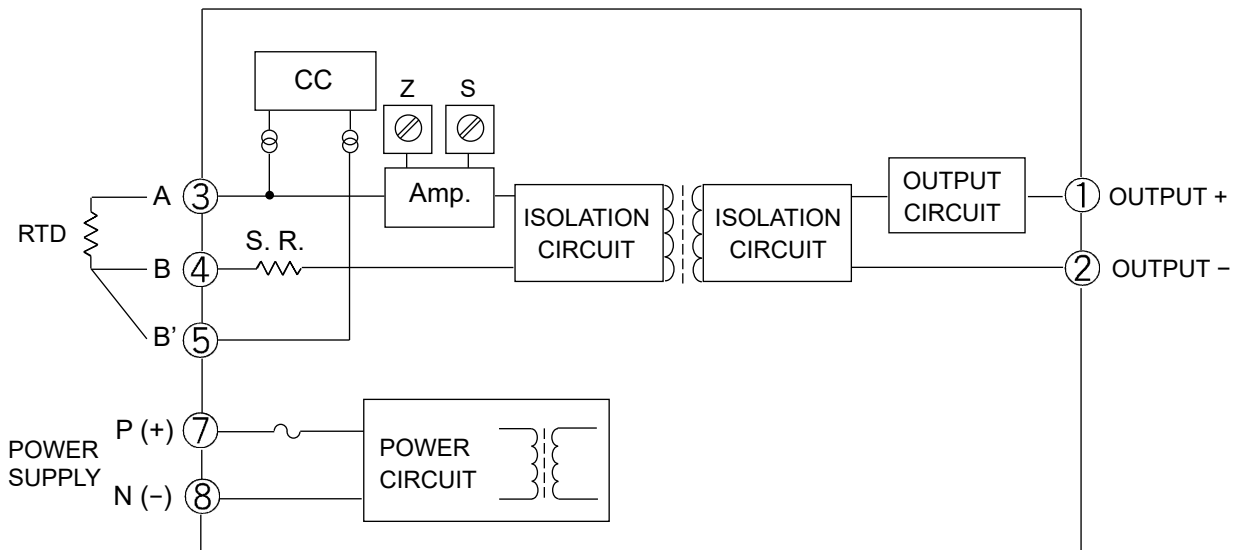

DESCRIPTION

The MS5503 is a plug-in millivolt (mV) isolator that converts mV input signals from sensors or other devices into commonly used DC signals and provides an isolated single output.

ORDERING CODE

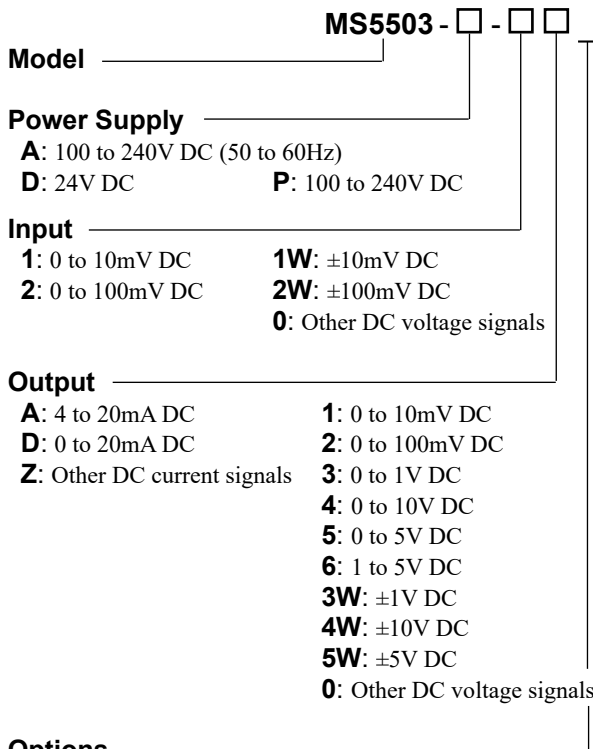

- MS5503 - [] - [] - []**
- A:** 100 to 240V DC (50 to 60Hz)
D: 24V DC **P:** 100 to 240V DC
- 1:** 0 to 10mV DC **1W:** ±10mV DC
2: 0 to 100mV DC **2W:** ±100mV DC
0: Other DC voltage signals
- A:** 4 to 20mA DC **1:** 0 to 10mV DC
D: 0 to 20mA DC **2:** 0 to 100mV DC
Z: Other DC current signals **3:** 0 to 1V DC
4: 0 to 10V DC
5: 0 to 5V DC
6: 1 to 5V DC
3W: ±1V DC
4W: ±10V DC
5W: ±5V DC
0: Other DC voltage signals

- Options** _____
- No code:** None
/K: Fast response (0 to 90% response time: 10ms max.)
/H: Polyurethane conformal coating
/X: Others (Special order)
 * For non-standard options, ask MTT for availability.

ORDERING INFORMATION

To place an order, please use the ordering code format as shown above.
 (e.g.) MS5503-A-2W4W/K

Other Ordering Examples:
 For an input code of "0": MS5503-A-06 (Input: 0 to 75mV)
 For an output code of "Z": MS5503-A-2Z (Output: 8 to 20mA)
 For an option code of "X": MS5503-A-26/X (Response frequency 50Hz)
 Note: If you wish to include multiple options in your order, specify the option codes in series (e.g. /KX).

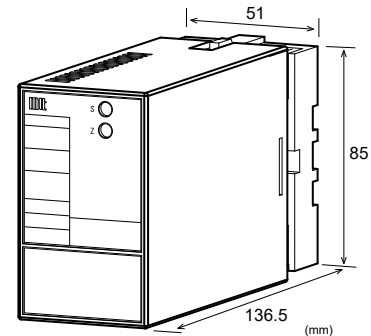

SPECIFICATIONS

POWER SECTION

Power Requirements	100 to 240V AC: 85 to 264V AC (47 to 63Hz) 24V DC: 24V DC±10% 100 to 240V DC: 85 to 264V DC		
Power Sensitivity	Better than ±0.1% of span for each power supply range.		
Power Line Fuse	160mA fuse		
Maximum Power Consumption			
Power	100-240V AC	24V DC	100-240V DC
	Approx. 4.0VA	Approx. 1.2W	Approx. 4.8W

INPUT SECTION

Input Resistance	1MΩ min. with or without power.		
Allowable Input Voltage	30V DC max., continuous.		
Range Available			
Input Range (DC)	-200mV to 200mV		
Input Span (DC)	5mV* to 400mV		
Input Bias	-100 to 100%		
Note: For any input range including negative input signals, the input span ranges from *10mV to 400mV.			
Input Spec Ex. 1:	For 50 to 150mV input, the input span is 100mV and the bias +50%.		
Input Spec Ex. 2:	For -10 to 30mV input, the input span is 40mV and the bias -25%.		

OUTPUT SECTION

Allowable Output Load		
Voltage Output (DC)	1V span and up	2mA max.
	10mV	10kΩ min.
	100mV	100kΩ min.
Current Output (DC)	4 to 20mA	750Ω max.
Zero Adjustment	Approx. ±5% of span. (Adjustable by the front-accessible trimmer.)	
Span Adjustment	Approx. ±5% of span. (Adjustable by the front-accessible trimmer.)	

Ranges Available

	Current Signal	Voltage Signal
Output Range (DC)	0 to 20mA	-10 to 10V
Output Span (DC)	4 to 20mA	10mV to 20V
Output Bias	0 to 100%	-100 to 100%

* For current output signals, the accuracy of any current output smaller than 0.1mA is not guaranteed.
 Output Spec Ex. 1: For 4 to 20mA output, the output span is 16mA and the bias +25%.
 Output Spec Ex. 2: For -1 to 4V output, the output span is 5V and the bias -20%.

PERFORMANCE

Accuracy Rating	Better than $\pm 0.1\%$ of span (at $25^{\circ}\text{C} \pm 5^{\circ}\text{C}$).
Temperature Effect	Better than $\pm 0.2\%$ of span per 10°C change in ambient.
Response Time	160ms max. (0 to 90%) with a step input at 100%.
CMRR	100dB min. (500V AC, 50/60Hz)
Isolation	3-way isolation between input, output, and power.
Insulation Resistance	100M Ω min. (@ 500V DC) between input, output, and power.
Dielectric Strength	Input / Output / Power: 2000V AC for 1 minute (Cutoff current: 0.5mA)
Surge Withstand Capability	Tested as per ANSI/IEEE C37.90.1-1989.
Operating Environment	Ambient temperature: -5 to 55°C Humidity: 5 to 90% RH (non-condensing)
Storage Temperature	-10 to 60°C

PHYSICAL

Installation	Wall/DIN rail mounting
Mounting Direction	Vertical
Screwing Torque	0.78 to 1.18 [Nm] * Recommended
Wiring	M3.5 screw terminal connection
External Dimensions	W51 x H85 x D136.5 mm (including the socket)
Weight	Main unit: 200g max. Socket: 60g max.

MATERIAL

Housing	ABS resin (UL 94V-0)
Socket	ABS resin (UL 94V-0)
Screw Terminal	Galvanized steel with trivalent chromate finish
Printed Circuit Board	Glass fabric, epoxy resin (FR-4: UL 94V-0)

TERMINAL ASSIGNMENTS

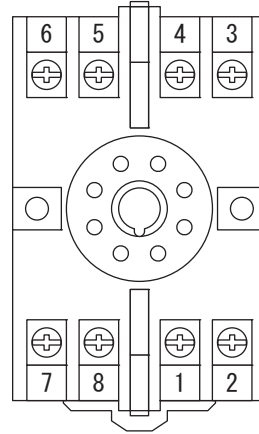

①	+ OUTPUT
②	- OUTPUT
③	+ INPUT
④	- INPUT
⑤	N.C.
⑥	N.C.
⑦	P (+)
⑧	N (-)

POWER

BLOCK DIAGRAM

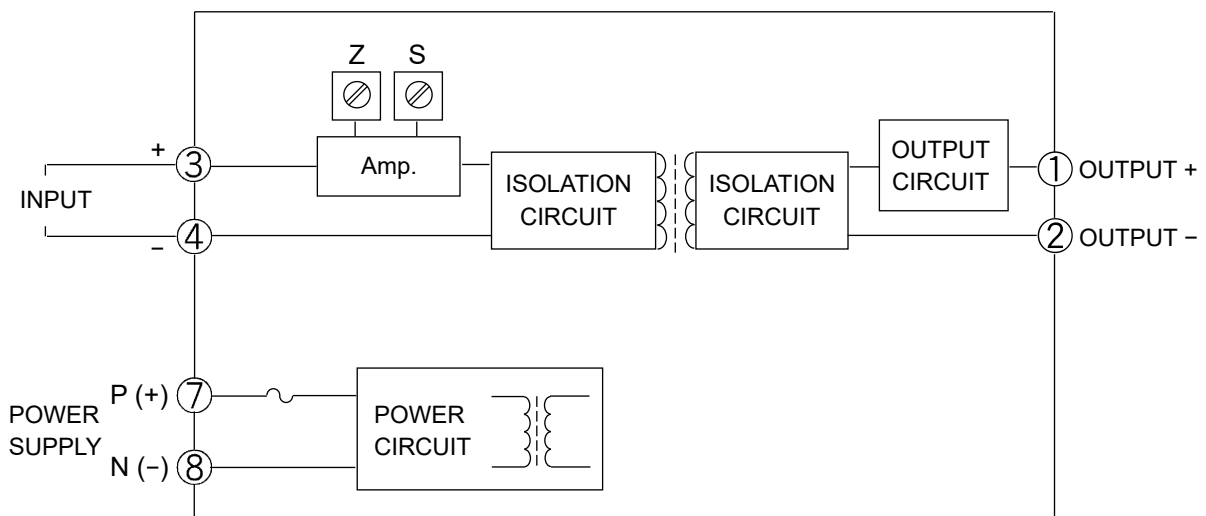

● OUTPUT SECTION

Allowable Output Load		
Voltage Output (DC)	1V span and up	2mA max.
	10mV	10kΩ min.
	100mV	100kΩ min.
Current Output (DC)	4 to 20mA	750Ω max.
Zero Adjustment	Approx. ±5% of span. (Adjustable by the front-accessible trimmer.)	
Span Adjustment	Approx. ±5% of span. (Adjustable by the front-accessible trimmer.)	
Ranges Available		
	Current Signal	Voltage Signal
Output Range (DC)	0 to 20mA	-10 to 10V
Output Span (DC)	4 to 20mA	10mV to 20V
Output Bias	0 to 100%	-100 to 100%
* For current output signals, the accuracy of any current output smaller than 0.1mA is not guaranteed.		
Output Spec. Ex. 1: For 4 to 20mA output, the output span is 16mA and the bias +25%.		
Output Spec. Ex. 2: For -1 to 4V output, the output span is 5V and the bias -20%.		

● PERFORMANCE

Accuracy Rating	Better than ±0.1% of span (at 25°C±5°C).
Temperature Effect	Better than ±0.2% of span per 10°C change in ambient.
Response Time	85ms max. (0 to 90%) with a step input at 100%.
CMRR	100dB min. (500V AC, 50/60Hz)
Isolation	3-way isolation between input, output, and power.
Insulation Resistance	100MΩ min. (@ 500V DC) between input, output, and power.
Dielectric Strength	Input / Output / Power: 2000V AC for 1 minute (Cutoff current: 0.5mA)
Surge Withstand Capability	Tested as per ANSI/IEEE C37.90.1-1989.
Operating Environment	Ambient temperature: -5 to 55°C Humidity: 5 to 90% RH (non-condensing)
Storage Temperature	-10 to 60°C

● PHYSICAL

Installation	Wall/DIN rail mounting
Mounting Direction	Vertical
Screwing Torque	0.78 to 1.18 [Nm] * Recommended
Wiring	M3.5 screw terminal connection
External Dimensions	W51 × H85 × D136.5 mm (including the socket)
Weight	Main unit: 200g max. Socket: 60g max.

● MATERIAL

Housing	ABS resin (UL 94V-0)
Socket	ABS resin (UL 94V-0)
Screw Terminal	Galvanized steel with trivalent chromate finish
Printed Circuit Board	Glass fabric, epoxy resin (FR-4: UL 94V-0)

TERMINAL ASSIGNMENTS

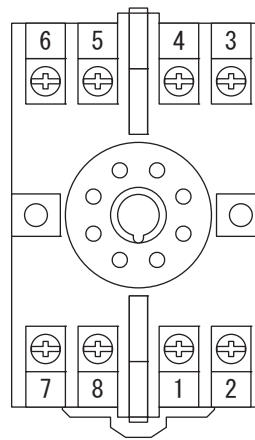

①	+ OUTPUT	
②	- OUTPUT	
③	+ INPUT	
④	- INPUT	
⑤	N.C.	
⑥	N.C.	
⑦	P (+)	POWER
⑧	N (-)	

BLOCK DIAGRAM

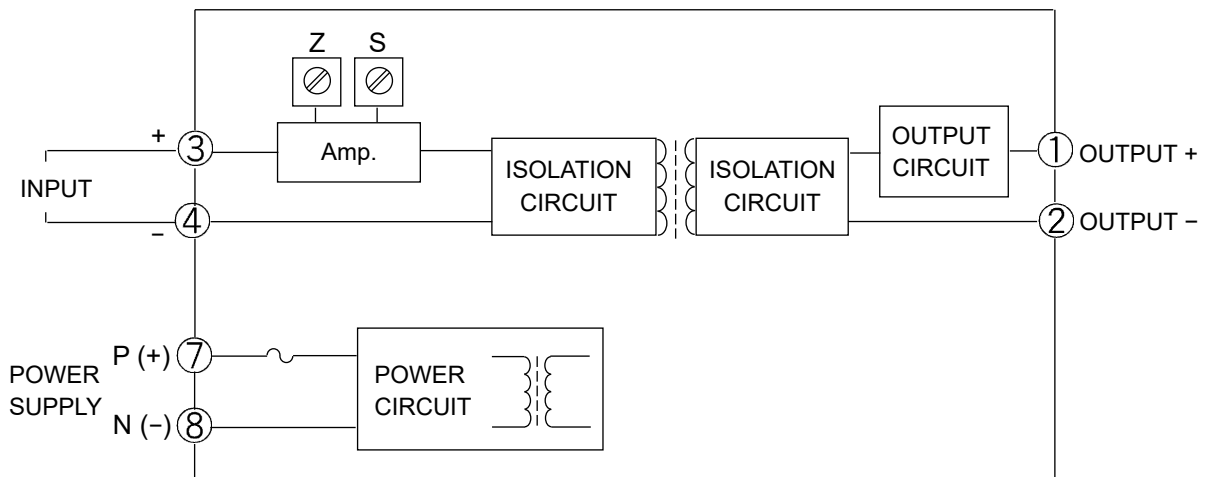

DESCRIPTION

The MS5505D is a plug-in digital alarm setter that compares the levels of DC current or voltage signals with two set-points (upper and lower limits) and outputs two independent isolated relay contact closure signals.

ORDERING CODE

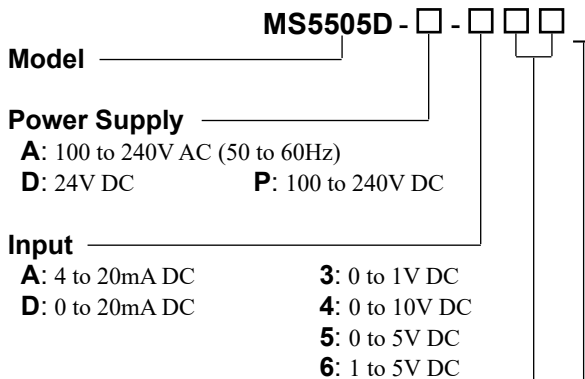

Relay Activation Modes for Output 1&2

Mode of operation for each channel can be selected from the following:

	With Power		Without Power
	Input < Set Value	Input > Set Value	
OH	OFF	ON	OFF
OL	ON	OFF	OFF
CH	ON	OFF	ON
CL	OFF	ON	ON

Note: The mode of operation cannot be changed by users.

Options

- No code:** None
- /K:** Fast response (0 to 90% response time: 100ms max.)
- /H:** Polyurethane conformal coating
- /X:** Others (Special order)
- * For non-standard options, ask MTT for availability.

ORDERING INFORMATION

To place an order, please use the ordering code format as shown above.

(e.g.) MS5505D-A-6OHOL

* The factory default trip point for both channels is 50% or equivalent of input span.

Other Ordering Examples:

For an option code of "X": MS5505D-A-6OHOL/X
 (Response time constant: T = 50ms with 90% setting)

For specific trip points*: MS5505D-A-6OHOL

- Trip point for Output 1: 40%
- Trip point for Output 2: 70%

* Specify values in % within the range of 0 to 99% of input span.

Note: If you wish to include multiple options in your order, specify the option codes in series (e.g. /KX).

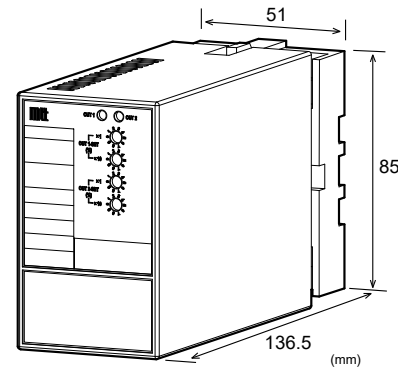

SPECIFICATIONS

POWER SECTION

Power Requirement	100 to 240V AC: 85 to 264V AC (47 to 63Hz)		
	24V DC: 24V DC±10%		
	100 to 240V DC: 85 to 264V DC		
Power Sensitivity	Better than ±0.1% of span for each power supply range.		
Power Line Fuse	160mA fuse		
Maximum Power Consumption			
Power	100-240V AC	24V DC	100-240V DC
	6.5VA	2.0W	8.4W

INPUT SECTION

Input Resistance			
Voltage Input (DC)	With power: 1MΩ min. Without power: 10kΩ min.		
Current Input (DC)	4 to 20mA (std.)	250Ω	
Allowable Input Voltage			
Voltage Input Model	30V DC max., continuous.		
Current Input Model	40mA DC max., continuous.		

OUTPUT SECTION

Output Signal	Two independent relay contact closure signals OH & OL: Form A contacts CH & CL: Form B contacts		
Trip Points Setting	Through the front-accessible rotary switches.		
Range	0 to 99% of span (in steps of 1%).		
Accuracy	±0.5% of span.		
Hysteresis	1.0%±0.3% of span		
Relay Indicator	OH & OL: The red LED lights up when the relay is ON. CH & CL: The red LED lights up when the relay is OFF.		
Relay Activation without Power	OH & OL: OFF CH & CL: ON		
Relay Start-up Limitation	The relay gets ready for action about 2 seconds after power-up.		

PERFORMANCE

Temperature Effect	Better than ±0.15% of span per 10°C change in ambient.
Response Time	150ms max. (0 to 90%) with a step input at 100%.
Isolation	Isolation between input, output 1, output 2, and power.
Insulation Resistance	100MΩ min. (@ 500V DC) between input, output 1, output 2, and power.
Dielectric Strength	Input / Output 1 / Output 2 / Power: 2000V AC for 1 minute (Cutoff current: 0.5mA)
Relay Contacts	
Rated Load	2A 125V AC, 2A 30V DC
Maximum Allowable Voltage	250V AC, 30V DC
Maximum Allowable Current	2A
Electrical Life	2A, 250V AC: 50 × 10 ³ cycles (Frequency: 1,800 cycles/h) 2A, 30V DC: 100 × 10 ³ cycles (Frequency: 1,800 cycles/h)
Mechanical Life	5 × 10 ⁶ cycles (Frequency: 18,000 cycles/h)
Surge Withstand Capability	Tested as per ANSI/IEEE C37.90.1-1989.
Operating Environment	Ambient temperature: -5 to 55°C Humidity: 5 to 90% RH (non-condensing)
Storage Temperature	-10 to 60°C

PHYSICAL

Installation	Wall/DIN rail mounting
Mounting Direction	Vertical
Screwing Torque	0.78 to 1.18 [Nm] * Recommended
Wiring	M3.5 screw terminal connection
External Dimensions	W51 × H85 × D136.5 mm (including the socket)
Weight	Main unit: 210g max. Socket: 60g max.

MATERIAL

Housing	ABS resin (UL 94V-0)
Socket	ABS resin (UL 94V-0)
Screw Terminal	Galvanized steel with trivalent chromate finish
Printed Circuit Board	Glass fabric, epoxy resin (FR-4: UL 94V-0)

TERMINAL ASSIGNMENTS

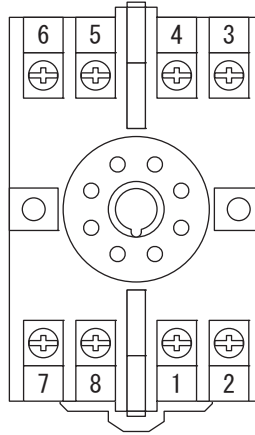

①	OUTPUT 1
②	OUTPUT 1
③	+ INPUT
④	- INPUT
⑤	OUTPUT 2
⑥	OUTPUT 2
⑦	P (+)
⑧	N (-)

POWER

BLOCK DIAGRAM

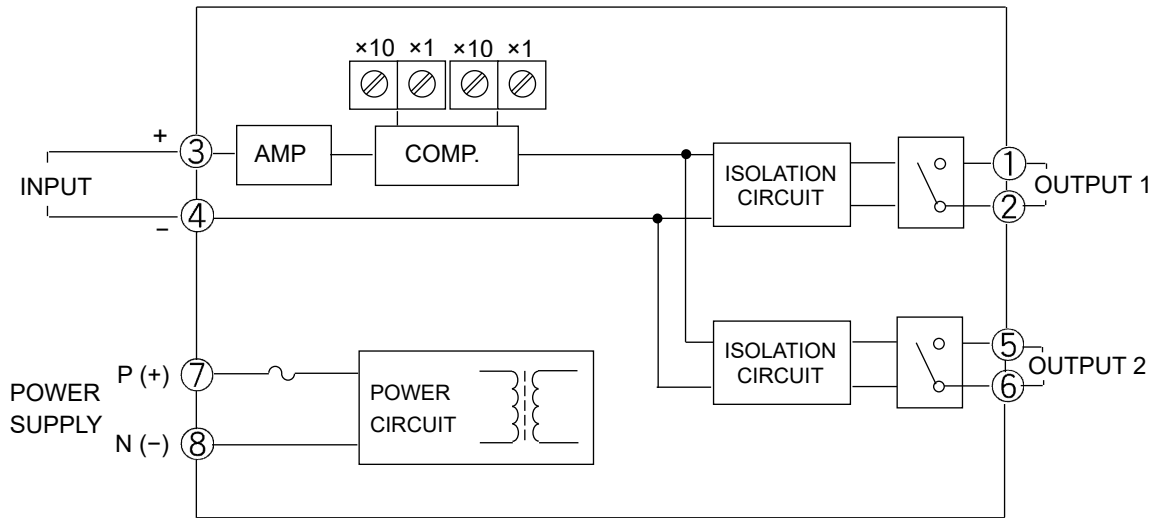

When an inductive load, such as an electric motor, is connected to the output, a relay contact protection circuit must be connected across the load.

Example of AC Power Connection:

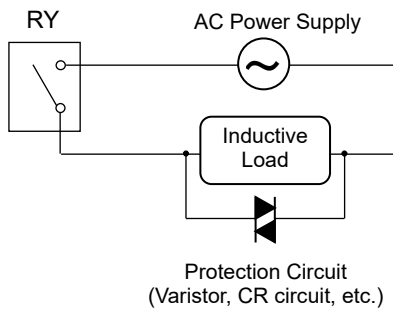

Example of DC Power Connection:

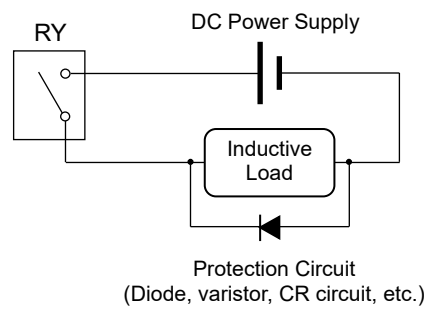

Ranges Available

	Current Signal	Voltage Signal
Output Range (DC)	0 to 20mA	-10 to 10V
Output Span (DC)	4 to 20mA	10mV to 20V
Output Bias	0 to 100%	-100 to 100%

* For current output signals, the accuracy of any current output smaller than 0.1mA is not guaranteed.
 Output Spec. Ex. 1: For 4 to 20mA output, the output span is 16mA and the bias +25%.
 Output Spec. Ex. 2: For -1 to 4V output, the output span is 5V and the bias -20%.

PERFORMANCE

Accuracy Rating	Better than $\pm 0.1\%$ of span (at $25^{\circ}\text{C} \pm 5^{\circ}\text{C}$).
Temperature Effect	Better than $\pm 0.2\%$ of span per 10°C change in ambient.
Response Time	85ms max. (0 to 90%) with a step input at 100%.
CMRR	100dB min. (500V AC, 50/60Hz)
Isolation	3-way isolation between input, output, and power.
Insulation Resistance	100M Ω min. (@ 500V DC) between input, output, and power.
Dielectric Strength	Input / Output / Power: 2000V AC for 1 minute (Cutoff current: 0.5mA)
Surge Withstand Capability	Tested as per ANSI/IEEE C37.90.1-1989.
Operating Environment	Ambient temperature: -5 to 55 $^{\circ}\text{C}$ Humidity: 5 to 90% RH (non-condensing)
Storage Temperature	-10 to 60 $^{\circ}\text{C}$

PHYSICAL

Installation	Wall/DIN rail mounting
Mounting Direction	Vertical
Screwing Torque	0.78 to 1.18 [Nm] * Recommended
Wiring	M3.5 screw terminal connection
External Dimensions	W51 x H85 x D136.5 mm (including the socket)
Weight	Main unit: 200g max. Socket: 60g max.

MATERIAL

Housing	ABS resin (UL 94V-0)
Socket	ABS resin (UL 94V-0)
Screw Terminal	Galvanized steel with trivalent chromate finish
Printed Circuit Board	Glass fabric, epoxy resin (FR-4: UL 94V-0)

TERMINAL ASSIGNMENTS

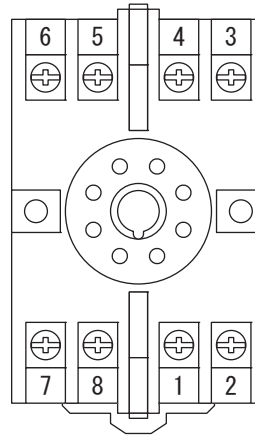

①	+ OUTPUT
②	- OUTPUT
③	+ INPUT
④	- INPUT
⑤	+ EX (Excitation voltage)
⑥	- EX (Excitation voltage)
⑦	P (+)
⑧	N (-)

POWER

BLOCK DIAGRAM

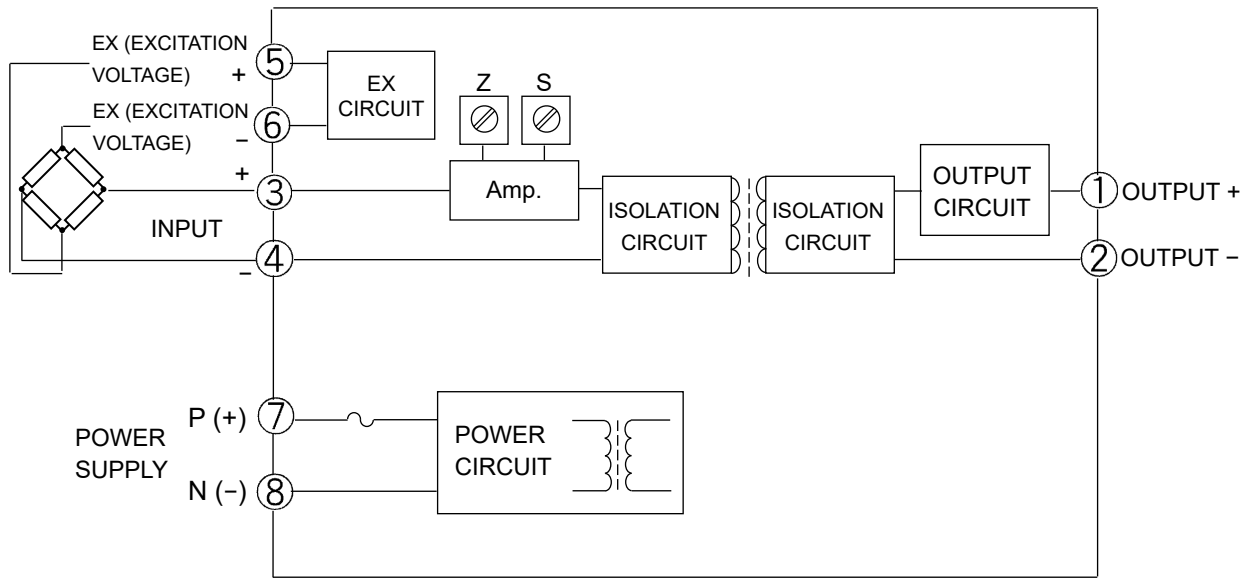

DESCRIPTION

The MS5507 is a plug-in distributor that powers a two-wire transmitter, converts its 4 to 20mA signals into commonly used DC signals, and provides an isolated single output. This model can also be used as an isolator.

ORDERING CODE

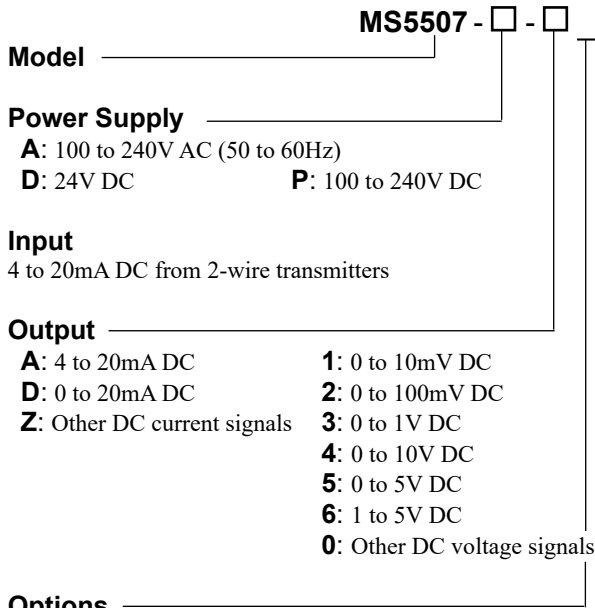

A: 100 to 240V AC (50 to 60Hz)
D: 24V DC **P:** 100 to 240V DC

Input
 4 to 20mA DC from 2-wire transmitters

Output

A: 4 to 20mA DC	1: 0 to 10mV DC
D: 0 to 20mA DC	2: 0 to 100mV DC
Z: Other DC current signals	3: 0 to 1V DC
	4: 0 to 10V DC
	5: 0 to 5V DC
	6: 1 to 5V DC
	0: Other DC voltage signals

Options

No code: None
/K: Fast response (0 to 90% response time: 10ms max.)
/H: Polyurethane conformal coating
/X: Others (Special order)
 * For non-standard options, ask MTT for availability.

ORDERING INFORMATION

To place an order, please use the ordering code format as shown above.
 (e.g.) MS5507-A-A/K

Other Ordering Examples:
 For an output code of "0": MS5507-A-0 (Output: 2 to 5V)
 For an option code of "X": MS5507-A-A/X (Response frequency: 50Hz)
 Note: If you wish to include multiple options in your order, specify the option codes in series (e.g. /KX).

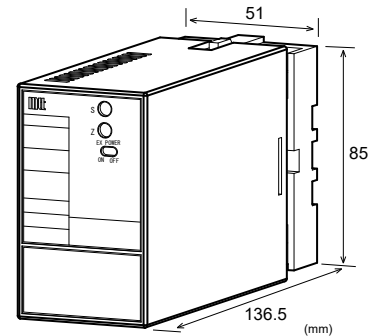

SPECIFICATIONS

● **POWER SECTION**

Power Requirements	100 to 240V AC: 85 to 264V AC (47 to 63Hz) 24V DC: 24V DC±10%			
Power Sensitivity	Better than ±0.1% of span for each power supply range.			
Power Line Fuse	160mA fuse			
Maximum Power Consumption	Power	100-240V AC	24V DC	100-240V DC
		Approx. 6.5VA	Approx. 2.1W	Approx. 7.2W

● **INPUT SECTION**

Input Signal	4 to 20mA DC from 2-wire transmitters
Input Resistance	250Ω
Transmitter Power Supply	Output voltage: 26.4V, typical. (0% input) 21.6V, typical. (100% input) Maximum current: 22mA, typical.
Limit Current for Short-Circuit Protection	40mA max.
Permissible Short-Circuit Duration	Continuous.

● **OUTPUT SECTION**

Allowable Output Load	Voltage Output (DC)	1V span and up 10mV 100mV	2mA max. 10kΩ min. 100kΩ min.
	Current Output (DC)	4 to 20mA	750Ω max.
Zero Adjustment	Approx. ±5% of span. (Adjustable by the front-accessible trimmer.)		
Span Adjustment	Approx. ±5% of span. (Adjustable by the front-accessible trimmer.)		

Ranges Available

	Current Signal	Voltage Signal
Output Range (DC)	0 to 20mA	0 to 10V
Output Span (DC)	4 to 20mA	10mV to 10V
Output Bias	0 to 100%	0 to 100%

* For current output signals, the accuracy of any current output smaller than 0.1mA is not guaranteed.
 Output Spec. Ex. 1: For 4 to 20mA output, the output span is 16mA and the bias +25%.
 Output Spec. Ex. 2: For 4 to 8V output, the output span is 4V and the bias +100%.

PERFORMANCE

Accuracy Rating	Better than ±0.1% of span (at 25°C±5°C).
Temperature Effect	Better than ±0.2% of span per 10°C change in ambient.
Response Time	85ms max. (0 to 90%) with a step input at 100%.
CMRR	100dB min. (500V AC, 50/60Hz)
Isolation	3-way isolation between input, output, and power.
Insulation Resistance	100MΩ min. (@ 500V DC) between input, output, and power.
Dielectric Strength	Input / Output / Power: 2000V AC for 1 minute (Cutoff current: 0.5mA)
Surge Withstand Capability	Tested as per ANSI/IEEE C37.90.1-1989.
Operating Environment	Ambient temperature: -5 to 55°C Humidity: 5 to 90% RH (non-condensing)
Storage Temperature	-10 to 60°C

PHYSICAL

Installation	Wall/DIN rail mounting
Mounting Direction	Vertical
Screwing Torque	0.78 to 1.18 [Nm] * Recommended
Wiring	M3.5 screw terminal connection
External Dimensions	W51 × H85 × D136.5 mm (including the socket)
Weight	Main unit: 200g max. Socket: 60g max.

MATERIAL

Housing	ABS resin (UL 94V-0)
Socket	ABS resin (UL 94V-0)
Screw Terminal	Galvanized steel with trivalent chromate finish
Printed Circuit Board	Glass fabric, epoxy resin (FR-4: UL 94V-0)

TERMINAL ASSIGNMENTS

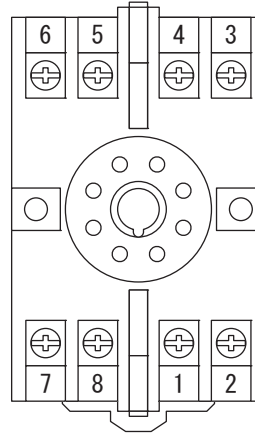

①	+ OUTPUT	
②	- OUTPUT	
③	- INPUT	
④	COM	
⑤	N.C.	
⑥	+ INPUT	
⑦	P (+)	POWER
⑧	N (-)	

BLOCK DIAGRAM

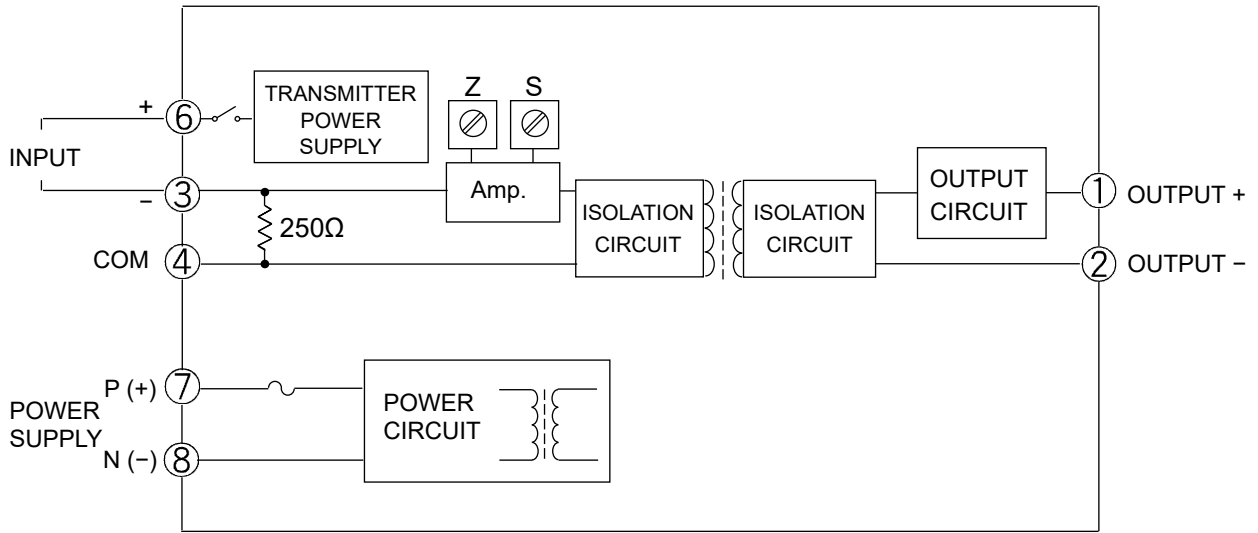

When used as a distributor:

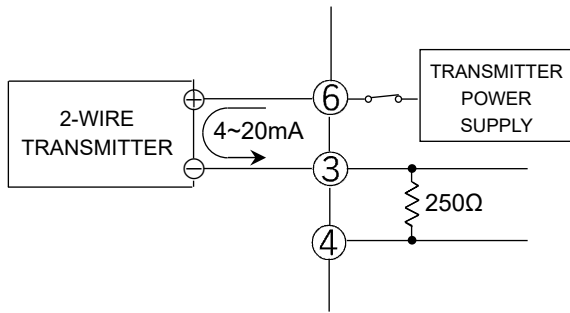

When used as an isolator:

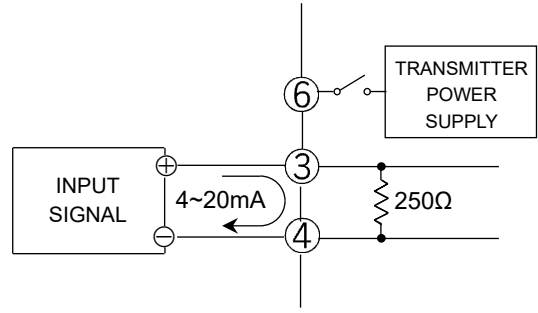

DESCRIPTION

The MS5508 is a plug-in frequency to analog converter that converts pulse train signals from flow sensors and the like into commonly used DC signals and provides an isolated single output.

ORDERING CODE

Model MS5508 - -

Power Supply _____

A: 100 to 240V AC (50 to 60Hz)
D: 24V DC **P:** 100 to 240V DC

Input _____

O: Dry contact or open collector
(Pull-up: Approx. 13V, 3.3kΩ)
A: AC voltage pulse
(Threshold voltage: Approx. 0.06Vp-p)
D: DC voltage pulse
(Threshold voltage: Approx. 2V)
I: 4 to 20mA DC pulse
(Threshold current: Approx. 8mA)
Y: Other input signals and/or threshold voltages

Output _____

A: 4 to 20mA DC **1:** 0 to 10mV DC
D: 0 to 20mA DC **2:** 0 to 100mV DC
Z: Other DC current signals **3:** 0 to 1V DC
 4: 0 to 10V DC
 5: 0 to 5V DC
 6: 1 to 5V DC
 3W: ±1V DC
 4W: ±10V DC
 5W: ±5V DC
 0: Other DC voltage signals

Options

No code: None

/A: Sensor power supply: 24V DC (±10%), 2-wire type

/B: Sensor power supply: 12V DC (±10%), 2-wire type

/C: Sensor power supply: 24V DC (±10%), 3-wire type

/D: Sensor power supply: 12V DC (±10%), 3-wire type

/E: Sensor power supply: 5V DC (±10%), 2-wire type

/F: Sensor power supply: 5V DC (±10%), 3-wire type

/H: Polyurethane conformal coating

/X: Others (Special order)

* For non-standard options, ask MTT for availability.

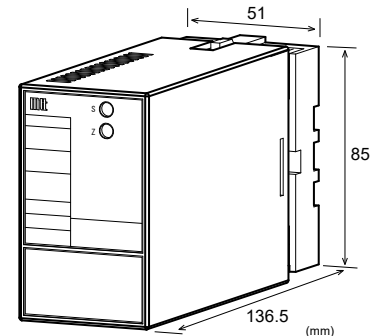
ORDERING INFORMATION

To place an order, please use the ordering code format as shown on the left. Also specify a measuring frequency range.

(e.g.) MS5508-A-AA (0 to 850Hz)

Other Ordering Examples:

For an input code of "Y": MS5508-A-YA (0 to 500Hz /

Input DC voltage pulse: 0 to 12V / SH = 8.5V, SL = 2.5V)

For an input code of "Y": MS5508-A-YA (0 to 500Hz /

Input AC voltage pulse: 200Vp-p / S = 2Vp-p)

* SH = Threshold level HI, SL = Threshold level LO,

S = Threshold level

Note: For DC current pulse input, the range should be specified between 0-100µA and 0-100mA.

SPECIFICATIONS
POWER SECTION

Power Requirements	100 to 240V AC: 85 to 264V AC (47 to 63Hz)
	24V DC: 24V DC±10%
	100 to 240V DC: 85 to 264V DC

Power Sensitivity	Better than ±0.1% of span for each power supply range.
-------------------	--

Power Line Fuse	160mA fuse
-----------------	------------

Maximum Power Consumption

Power	100-240V AC	24V DC	100-240V DC
	Approx. 8.3VA	Approx. 2.6W	Approx. 8.3W

INPUT SECTION
Input Resistance

Voltage Input Model (DC)	With power:	1MΩ min. (Standard, 5V input)
	Without power:	30kΩ min.

Current Input Model (DC)	250Ω (Standard for 4 to 20mA)
--------------------------	-------------------------------

Note: When a 2-wire type sensor power supply is specified, a shunt resistor of 100Ω is used.

Allowable Input Voltage

DC Voltage Input Model	30V DC max., continuous.
DC Current Input Model	40mA DC max., continuous.
AC Voltage Input Model	200Vp-p AC max., continuous (up to ±100V with reference to 0V).

Input Pulse Width	20 μ s min.	
Duty Ratio	40 to 60%	
Maximum Sensor Supply Current	30mA	
Ranges Available	AC Voltage Pulse	DC Voltage Pulse
Input Range	-300 to 300V	0 to 300V
Input Voltage Span	0.1 to 600V _{p-p}	1 to 300V
Input Bias	N/A	0 to +300%
Threshold Voltage	50mV _{p-p} min.	Hi-Lo voltage: 0.2V min.
Input Frequency	Within the range between 0-20Hz and 0-20kHz.	

Input Spec. Ex.: For 10 to 15V DC voltage pulse input, the input voltage span is 5V and the bias +200%.

● OUTPUT SECTION

Allowable Output Load		
Voltage Output (DC)	1V span and up	2mA max.
	10mV	10k Ω min.
	100mV	100k Ω min.
Current Output (DC)	4 to 20mA	750 Ω max.
Zero Adjustment	Approx. \pm 5% of span. (Adjustable by the front-accessible trimmer.)	
Span Adjustment	Approx. \pm 5% of span. (Adjustable by the front-accessible trimmer.)	
Ranges Available		
	Current Signal	Voltage Signal
Output Range (DC)	0 to 20mA	-10 to 10V
Output Span (DC)	4 to 20mA	10mV to 20V
Output Bias	0 to 100%	-100 to 100%
* For current output signals, the accuracy of any current output smaller than 0.1mA is not guaranteed.		
Output Spec. Ex. 1: For 4 to 20mA output, the output span is 16mA and the bias +25%.		
Output Spec. Ex. 2: For -1 to 4V output, the output span is 5V and the bias -20%.		

● PERFORMANCE

Accuracy Rating	Better than \pm 0.3% of span. Ripple: 0.2%p-p or less of span (for at least 10% input) (at 25 $^{\circ}$ C \pm 5 $^{\circ}$ C)
Temperature Effect	Better than \pm 0.2% of span per 10 $^{\circ}$ C change in ambient.
Response Time	
Input Frequency	0 to 90% with a step input at 100%
20Hz	8s max.
200Hz	1s max.
2kHz	500ms max.
20kHz	500ms max.
CMRR	100dB min. (500V AC, 50/60Hz)
Isolation	3-way isolation between input, output, and power.
Insulation Resistance	100M Ω min. (@ 500V DC) between input, output, and power.
Dielectric Strength	Input / Output / Power: 2000V AC for 1 minute (Cutoff current: 0.5mA)
Surge Withstand Capability	Tested as per ANSI/IEEE C37.90.1-1989.
Operating Environment	Ambient temperature: -5 to 55 $^{\circ}$ C Humidity: 5 to 90% RH (non-condensing)
Storage Temperature	-10 to 60 $^{\circ}$ C

● PHYSICAL

Installation	Wall/DIN rail mounting
Mounting Direction	Vertical
Screwing Torque	0.78 to 1.18 [Nm] * Recommended
Wiring	M3.5 screw terminal connection
External Dimensions	W51 \times H85 \times D136.5 mm (including the socket)
Weight	Main unit: 200g max. Socket: 60g max.

● MATERIAL

Housing	ABS resin (UL 94V-0)
Socket	ABS resin (UL 94V-0)
Screw Terminal	Galvanized steel with trivalent chromate finish
Printed Circuit Board	Glass fabric, epoxy resin (FR-4: UL 94V-0)

TERMINAL ASSIGNMENTS

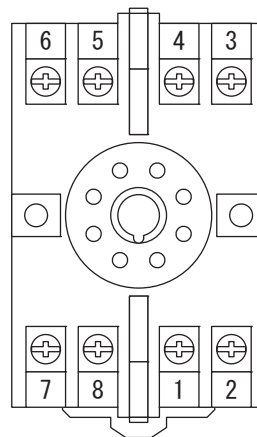

①	+ OUTPUT	
②	- OUTPUT	
③	+ INPUT	
④	- INPUT	
⑤	EX +	
⑥	N.C.	
⑦	P (+)	POWER
⑧	N (-)	

BLOCK DIAGRAM

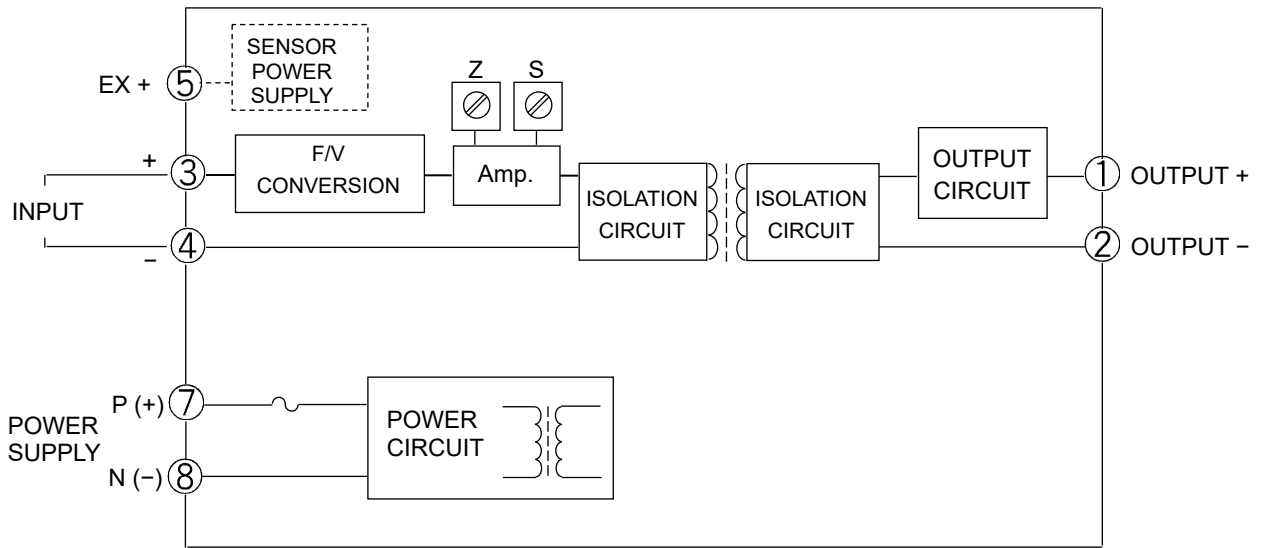

For dry contact or open collector input:

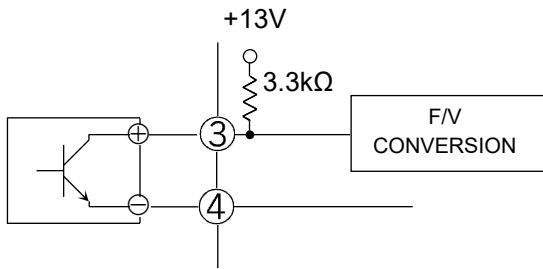

For voltage pulse input:

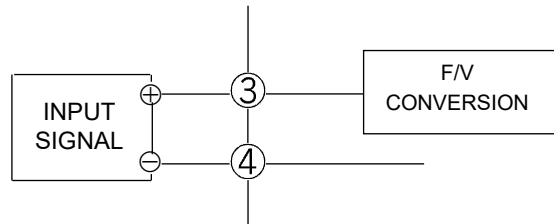

When a 2-wire sensor is used:

Note: The connections may vary depending on the type of the sensor used.

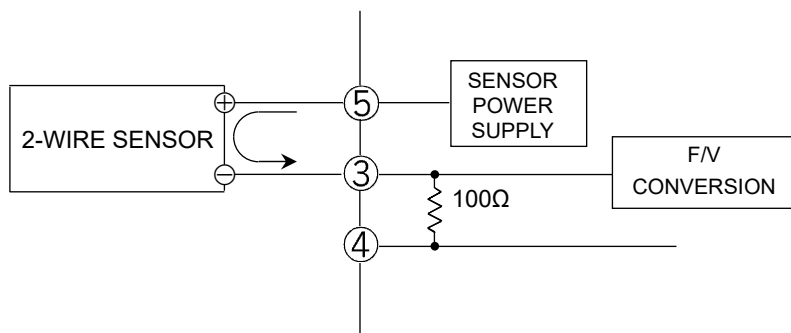

DESCRIPTION

The MS5510 is a plug-in potentiometer transmitter that detects changes in the resistance of potentiometric sensors, converts them into commonly used DC signals and provides an isolated single output.

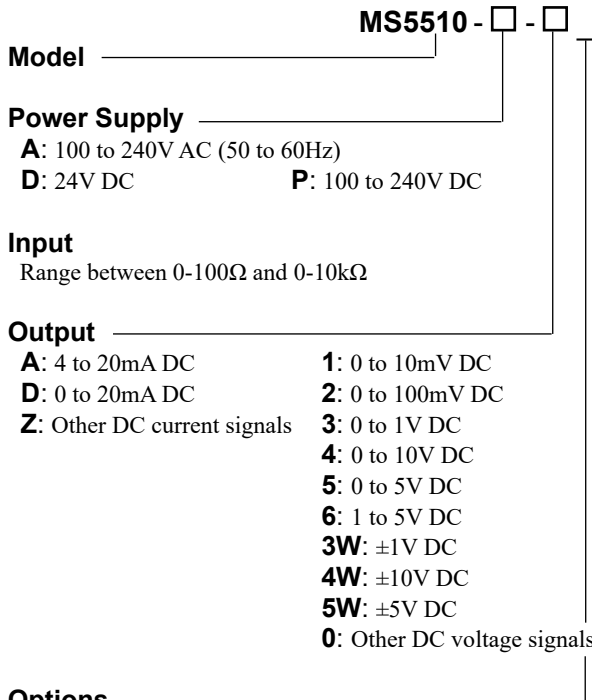
ORDERING CODE

MS5510 - [] - []

Power Supply

A: 100 to 240V AC (50 to 60Hz)
D: 24V DC **P:** 100 to 240V DC

Input
 Range between 0-100Ω and 0-10kΩ

Output

A: 4 to 20mA DC **1:** 0 to 10mV DC
D: 0 to 20mA DC **2:** 0 to 100mV DC
Z: Other DC current signals **3:** 0 to 1V DC
 4: 0 to 10V DC
 5: 0 to 5V DC
 6: 1 to 5V DC
 3W: ±1V DC
 4W: ±10V DC
 5W: ±5V DC
 0: Other DC voltage signals

Options

No code: None
/K: Fast response (0 to 90% response time: 10ms max.)
/H: Polyurethane conformal coating
/X: Others (Special order)
 * For non-standard options, ask MTT for availability.

ORDERING INFORMATION

To place an order, please use the ordering code format as shown above.
 (e.g.) MS5510-A-4/K
 * Factory adjustment of resistance range: Specify a resistance range if required (e.g. 0 to 1kΩ); otherwise, products will be supplied with a factory-adjusted resistance range of 0 to 10kΩ.

Other Ordering Examples:
 For an output code of "0": MS5510-A-0 (Output: 2 to 5V)
 For a specific resistance range: MS5510-A-A (0 to 500Ω)
 (When you specify a resistance range, our factory performs the test accordingly, the fact of which will be indicated in the label attached.)
 For an option code of "X": MS5510-A-A/X (Response frequency: 50Hz)
 Note: If you wish to include multiple options in your order, specify the option codes in series (e.g. /KX).

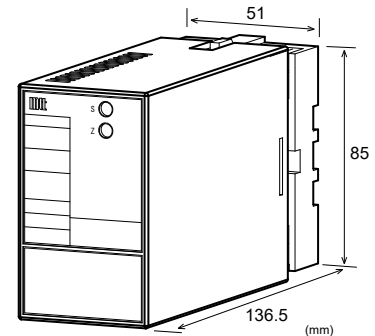
SPECIFICATIONS
POWER SECTION

Power Requirements	100 to 240V AC: 85 to 264V AC (47 to 63Hz) 24V DC: 24V DC±10% 100 to 240V DC: 85 to 264V DC		
Power Sensitivity	Better than ±0.1% of span for each power supply range.		
Power Line Fuse	160mA fuse		
Maximum Power Consumption			
Power	100-240V AC	24V DC	100-240V DC
	Approx. 4.5VA	Approx. 1.1W	Approx. 4.8W

INPUT SECTION

Input Signal	Range between 0-100Ω and 0-10kΩ.
Measuring Voltage	Approx. 0.5V
Allowable Lead Wire Resistance	10% or less of total resistance per wire. (The resistance of all three wires must be equal.)

OUTPUT SECTION

Allowable Output Load		
Voltage Output (DC)	1V span and up 10mV 100mV	2mA max. 10kΩ min. 100kΩ min.
Current Output (DC)	4 to 20mA	750Ω max.
Zero Adjustment	Approx. 0 to 50% of total resistance. (Adjustable by the front-accessible trimmer.)	
Span Adjustment	Approx. 50 to 100% of total resistance. (Adjustable by the front-accessible trimmer.)	

Ranges Available	Current Signal	Voltage Signal
Output Range (DC)	0 to 20mA	-10 to 10V
Output Span (DC)	4 to 20mA	10mV to 20V
Output Bias	0 to 100%	-100 to 100%
* For current output signals, the accuracy of any current output smaller than 0.1mA is not guaranteed.		
Output Spec. Ex. 1: For 4 to 20mA output, the output span is 16mA and the bias +25%.		
Output Spec. Ex. 2: For -1 to 4V output, the output span is 5V and the bias -20%.		

● PERFORMANCE

Accuracy Rating	Better than ±0.2% of span (at 25°C±5°C).
Temperature Effect	Better than ±0.2% of span per 10°C change in ambient.
Response Time	170ms max. (0 to 90%) with a step input at 100%.
CMRR	100dB min. (500V AC, 50/60Hz)
Isolation	3-way isolation between input, output, and power.
Insulation Resistance	100MΩ min. (@ 500V DC) between input, output, and power.
Dielectric Strength	Input / Output / Power: 2000V AC for 1 minute (Cutoff current: 0.5mA)
Surge Withstand Capability	Tested as per ANSI/IEEE C37.90.1-1989.
Operating Environment	Ambient temperature: -5 to 55°C Humidity: 5 to 90% RH (non-condensing)
Storage Temperature	-10 to 60°C

● PHYSICAL

Installation	Wall/DIN rail mounting
Mounting Direction	Vertical
Screwing Torque	0.78 to 1.18 [Nm] * Recommended
Wiring	M3.5 screw terminal connection
External Dimensions	W51 × H85 × D136.5 mm (including the socket)
Weight	Main unit: 200g max. Socket: 60g max.

● MATERIAL

Housing	ABS resin (UL 94V-0)
Socket	ABS resin (UL 94V-0)
Screw Terminal	Galvanized steel with trivalent chromate finish
Printed Circuit Board	Glass fabric, epoxy resin (FR-4: UL 94V-0)

TERMINAL ASSIGNMENTS

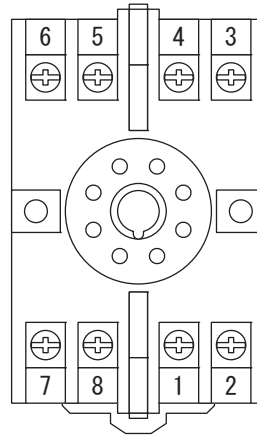

①	+ OUTPUT
②	- OUTPUT
③	POT A
④	POT B
⑤	POT C
⑥	N.C.
⑦	P (+)
⑧	N (-)

BLOCK DIAGRAM

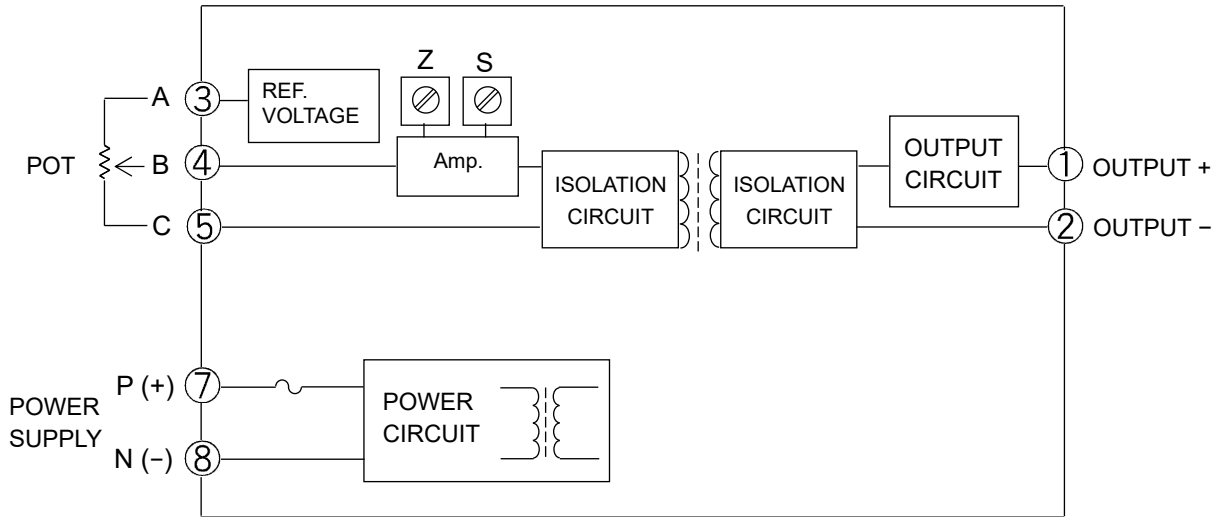

DESCRIPTION

The MS5513 is a plug-in square-root extractor that extracts the square roots of DC current or voltage signals, converts them into commonly used DC signals and provides an isolated single output.

ORDERING CODE

Model _____ **MS5513** - □ - □ □

Power Supply _____

A: 100 to 240V AC (50 to 60Hz)
D: 24V DC **P:** 100 to 240V DC

Input _____

A: 4 to 20mA DC **3:** 0 to 1V DC
B: 2 to 10mA DC **4:** 0 to 10V DC
C: 1 to 5mA DC **5:** 0 to 5V DC
D: 0 to 20mA DC **6:** 1 to 5V DC
E: 4 to 20mA DC*1 **0:** Other DC voltage signals
H: 10 to 50mA DC
Z: Other DC current signals

*1: Shunt resistor 50Ω

Output _____

A: 4 to 20mA DC **1:** 0 to 10mV DC
D: 0 to 20mA DC **2:** 0 to 100mV DC
Z: Other DC current signals **3:** 0 to 1V DC
 4: 0 to 10V DC
 5: 0 to 5V DC
 6: 1 to 5V DC
 3W: ±1V DC
 4W: ±10V DC
 5W: ±5V DC
 0: Other DC voltage signals

Options _____

No code: None
/H: Polyurethane conformal coating
/X: Others (Special order)
* For non-standard options, ask MTT for availability.

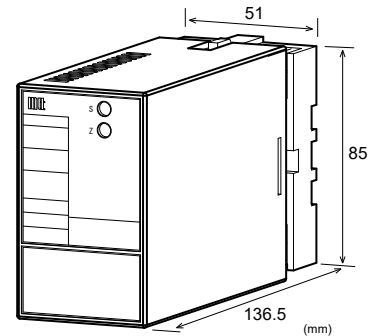

SPECIFICATIONS

POWER SECTION

Power Requirement	100 to 240V AC: 85 to 264V AC (47 to 63Hz) 24V DC: 24V DC±10% 100 to 240V DC: 85 to 264V DC		
Power Sensitivity	Better than ±0.1% of span for each power supply range.		
Power Line Fuse	160mA fuse		
Maximum Power Consumption			
Power	100-240V AC	24V DC	100-240V DC
	Approx. 5.5VA	Approx. 1.6W	Approx. 6.0W

INPUT SECTION

Input Resistance		
Voltage Input (DC)	1MΩ min. with or without power.	
Current Input (DC)	4 to 20mA (std.)	250Ω
	2 to 10mA	250Ω
	1 to 5 mA	100Ω
	0 to 20mA	250Ω
	10 to 50mA	10Ω
Allowable Input Voltage		
Voltage Input Model	30V DC max., continuous. (Standard for a span up to 10V)	
Current Input Model	40mA DC max., continuous. (Standard for 4 to 20mA)	
Ranges Available		
	Current Signal	Voltage Signal
Input Range (DC)	0 to 100mA	0 to 300V
Input Span (DC)	100μA to 100mA	200mV to 300V
Input Bias	0 to 100%	0 to 100%
Input Spec. Ex. 1: For 4 to 20mA input, the input span is 16mA and the bias +25%.		
Input Spec. Ex. 2: For 2 to 6V input, the input span is 4V and the bias +50%.		

ORDERING INFORMATION

To place an order, please use the ordering code format as shown above.
(e.g.) MS5513-A-6A

Other Ordering Examples:
For an input code of "0": MS5513-D-04 (Input: 2 to 5V)
For an output code of "Z": MS5513-A-EZ (Output: 8 to 20mA)

● OUTPUT SECTION

Allowable Output Load		
Voltage Output (DC)	1V span and up 10mV 100mV	2mA max. 10kΩ min. 100kΩ min. 750Ω max.
Current Output (DC)	4 to 20mA	
Zero Adjustment	Approx. ±5% of span. (Adjustable by the front-accessible trimmer.)	
Span Adjustment	Approx. ±5% of span. (Adjustable by the front-accessible trimmer.)	
Square-Root Extraction	$X = 10 \times \sqrt{Y}$ where X = Output signal (0 to 100%) Y = Input signal (0 to 100%) Note: The cutoff function works when the output is less than or equal to 8%±1%.	

Ranges Available

	Current Signal	Voltage Signal
Output Range (DC)	0 to 20mA	-10 to 10V
Output Span (DC)	4 to 20mA	10mV to 20V
Output Bias	0 to 100%	-100 to 100%

* For current output signals, the accuracy of any current output smaller than 0.1mA is not guaranteed.
 Output Spec. Ex. 1: For 4 to 20mA output, the output span is 16mA and the bias +25%.
 Output Spec. Ex. 2: For -1 to 4V output, the output span is 5V and the bias -20%.

● PERFORMANCE

Accuracy Rating	Better than ±0.2% of span (1 to 100% input at 25°C±5°C)
Temperature Effect	Better than ±0.2% of span per 10°C change in ambient.
Response Time	120ms max. (0 to 90%) with a step input at 100%.
CMRR	100dB min. (500V AC, 50/60Hz)
Isolation	3-way isolation between input, output, and power.
Insulation Resistance	100MΩ min. (@ 500V DC) between input, output, and power.
Dielectric Strength	Input / Output / Power: 2000V AC for 1 minute (Cutoff current: 0.5mA)
Surge Withstand Capability	Tested as per ANSI/IEEE C37.90.1-1989.
Operating Environment	Ambient temperature: -5 to 55°C Humidity: 5 to 90% RH (non-condensing)
Storage Temperature	-10 to 60°C

● PHYSICAL

Installation	Wall/DIN rail mounting
Mounting Direction	Vertical
Screwing Torque	0.78 to 1.18 [Nm] * Recommended
Wiring	M3.5 screw terminal connection
External Dimensions	W51 × H85 × D136.5 mm (including the socket)
Weight	Main unit: 200g max. Socket: 60g max.

● MATERIAL

Housing	ABS resin (UL 94V-0)
Socket	ABS resin (UL 94V-0)
Screw Terminal	Galvanized steel with trivalent chromate finish
Printed Circuit Board	Glass fabric, epoxy resin (FR-4: UL 94V-0)

TERMINAL ASSIGNMENTS

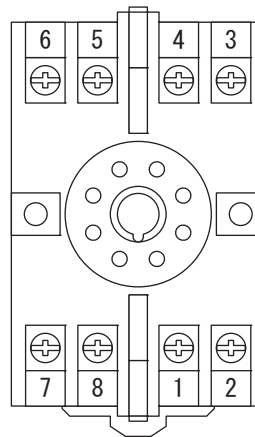

①	+ OUTPUT	
②	- OUTPUT	
③	+ INPUT	
④	- INPUT	
⑤	N.C.	
⑥	N.C.	
⑦	P (+)	POWER
⑧	N (-)	

BLOCK DIAGRAM

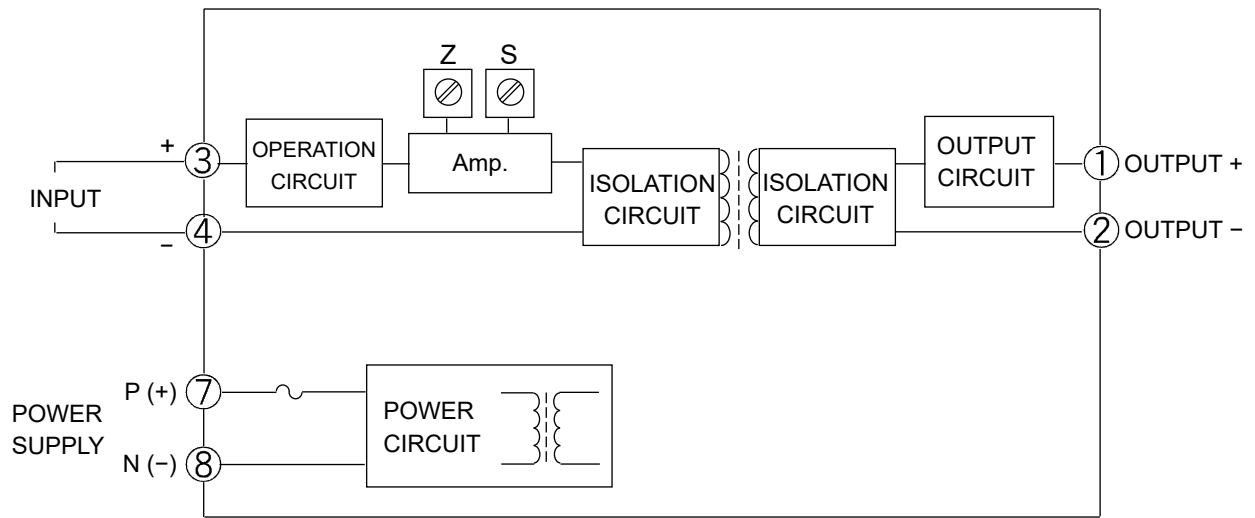

DESCRIPTION

The MS5520 is a plug-in CT transmitter that calculates the rms values of AC current signals from a CT, converts them into commonly used DC signals, and provides an isolated single output.

ORDERING CODE

Model _____ **MS5520** - □ - □ □

Power Supply _____

A: 100 to 240V AC (50 to 60Hz)
D: 24V DC **P:** 100 to 240V DC

Input (AC Current Signal) _____

1: 0 to 1A AC, 50/60Hz
5: 0 to 5A AC, 50/60Hz

Output _____

A: 4 to 20mA DC	1: 0 to 10mV DC
D: 0 to 20mA DC	2: 0 to 100mV DC
Z: Other DC current signals	3: 0 to 1V DC
	4: 0 to 10V DC
	5: 0 to 5V DC
	6: 1 to 5V DC
	3W: ±1V DC
	4W: ±10V DC
	5W: ±5V DC
	0: Other DC voltage signals

Options _____

No code: None
/H: Polyurethane conformal coating
/X: Others (Special order)
 * For non-standard options, ask MTT for availability.

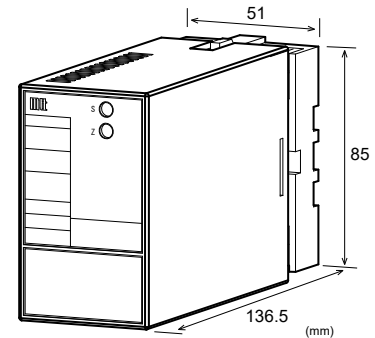

SPECIFICATIONS

POWER SECTION

Power Requirements	100 to 240V AC: 85 to 264V AC (47 to 63Hz) 24V DC: 24V DC±10% 100 to 240V DC: 85 to 264V DC		
Power Sensitivity	Better than ±0.1% of span for each power supply range.		
Power Line Fuse	160mA fuse		
Maximum Power Consumption			
Power	100-240V AC	24V DC	100-240V DC
	Approx. 4.5VA	Approx. 1.2W	Approx. 4.8W

INPUT SECTION

Input Resistance	5A AC input: 2mΩ (Shunt resistor) 1A AC input: 10mΩ (Shunt resistor)
Allowable Input Current	Continuous: 120% of the rated input value Instantaneous: 10 times the rated input value (within 3 seconds)
Crest Factor	3 max.

OUTPUT SECTION

Allowable Output Load		
Voltage Output (DC)	1V span and up 10mV 100mV	2mA max. 10kΩ min. 100kΩ min.
Current Output (DC)	4 to 20mA	750Ω max.
Zero Adjustment	Approx. ±5% of span. (Adjustable by the front-accessible trimmer.)	
Span Adjustment	Approx. ±5% of span. (Adjustable by the front-accessible trimmer.)	

Ranges Available

	Current Signal	Voltage Signal
Output Range (DC)	0 to 20mA	-10 to 10V
Output Span (DC)	4 to 20mA	10mV to 20V
Output Bias	0 to 100%	-100 to 100%

* For current output signals, the accuracy of any current output smaller than 0.1mA is not guaranteed.

Output Spec. Ex. 1: For 4 to 20mA output, the output span is 16mA and the bias +25%.

Output Spec. Ex. 2: For -1 to 4V output, the output span is 5V and the bias -20%.

ORDERING INFORMATION

To place an order, please use the ordering code format as shown above.
 (e.g.) MS5520-A-56

Other Ordering Examples:
 For an output code of "0": MS5520-A-10 (Output: 2 to 5V)
 For an option code of "X": MS5520-A-1A/X (0-90% response time: 100ms max.)

● PERFORMANCE

Accuracy Rating	Better than $\pm 0.25\%$ of span with at least 10% input (at $25^{\circ}\text{C} \pm 5^{\circ}\text{C}$).
Temperature Effect	Better than $\pm 0.2\%$ of span per 10°C change in ambient.
Response Time	400ms max. (0 to 90%) with a step input at 100%.
CMRR	100dB min. (500V AC, 50/60Hz)
Isolation	3-way isolation between input, output, and power.
Insulation Resistance	100M Ω min. (@ 500V DC) between input, output, and power.
Dielectric Strength	Input / Output / Power: 2000V AC for 1 minute (Cutoff current: 0.5mA)
Surge Withstand Capability	Tested as per ANSI/IEEE C37.90.1-1989.
Operating Environment	Ambient temperature: -5 to 55°C Humidity: 5 to 90% RH (non-condensing)
Storage Temperature	-10 to 60°C

● PHYSICAL

Installation	Wall/DIN rail mounting
Mounting Direction	Vertical
Screwing Torque	0.78 to 1.18 [Nm] * Recommended
Wiring	M3.5 screw terminal connection The supplied protector should be connected to the terminal block.
External Dimensions	$W51 \times H85 \times D136.5$ mm (including the socket, but not including the protector)
Weight	Main unit: 200g max. Socket: 60g max. Protector: 22g max.

● MATERIAL

Housing	ABS resin (UL 94V-0)
Socket	ABS resin (UL 94V-0)
Screw Terminal	Galvanized steel with trivalent chromate finish
Printed Circuit Board	Glass fabric, epoxy resin (FR-4: UL 94V-0)

TERMINAL ASSIGNMENTS

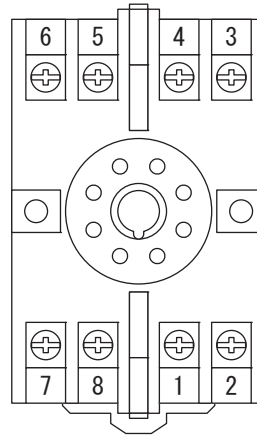

①	+ OUTPUT	
②	- OUTPUT	
③	L INPUT	
④	N INPUT	
⑤	N.C.	
⑥	N.C.	
⑦	P (+)	POWER
⑧	N (-)	

BLOCK DIAGRAM

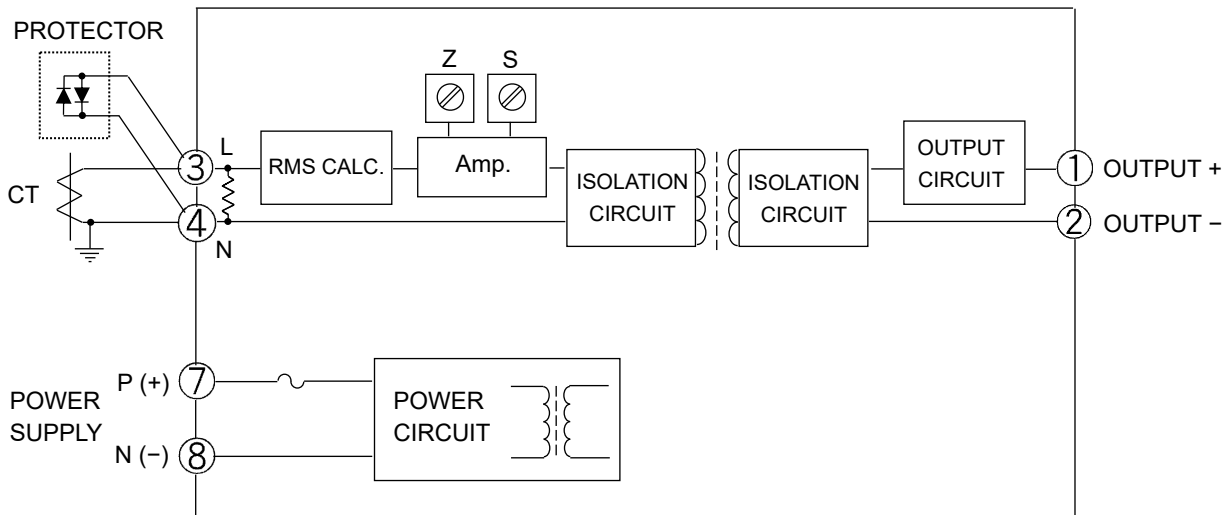

● PERFORMANCE

Accuracy Rating	Better than $\pm 0.25\%$ of span with at least 10% input (at $25^{\circ}\text{C} \pm 5^{\circ}\text{C}$).
Temperature Effect	Better than $\pm 0.2\%$ of span per 10°C change in ambient.
Response Time	400ms max. (0 to 90%) with a step input at 100%.
CMRR	100dB min. (500V AC, 50/60Hz)
Isolation	3-way isolation between input, output, and power.
Insulation Resistance	100M Ω min. (@ 500V DC) between input, output, and power.
Dielectric Strength	Input / Output / Power: 2000V AC for 1 minute (Cutoff current: 0.5mA)
Surge Withstand Capability	Tested as per ANSI/IEEE C37.90.1-1989.
Operating Environment	Ambient temperature: -5 to 55°C Humidity: 5 to 90% RH (non-condensing)
Storage Temperature	-10 to 60°C

● PHYSICAL

Installation	Wall/DIN rail mounting
Mounting Direction	Vertical
Screwing Torque	0.78 to 1.18 [Nm] * Recommended
Wiring	M3.5 screw terminal connection
External Dimensions	W51 x H85 x D136.5 mm (including the socket)
Weight	Main unit: 200g max. Socket: 60g max.

● MATERIAL

Housing	ABS resin (UL 94V-0)
Socket	ABS resin (UL 94V-0)
Screw Terminal	Galvanized steel with trivalent chromate finish
Printed Circuit Board	Glass fabric, epoxy resin (FR-4: UL 94V-0)

TERMINAL ASSIGNMENTS

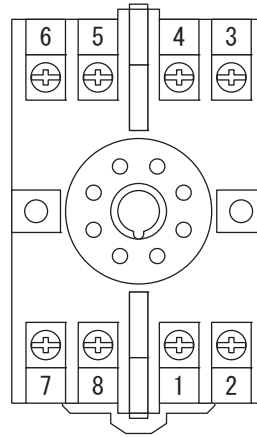

①	+ OUTPUT	
②	- OUTPUT	
③	L INPUT	
④	N INPUT	
⑤	N.C.	
⑥	N.C.	
⑦	P (+)	POWER
⑧	N (-)	

BLOCK DIAGRAM

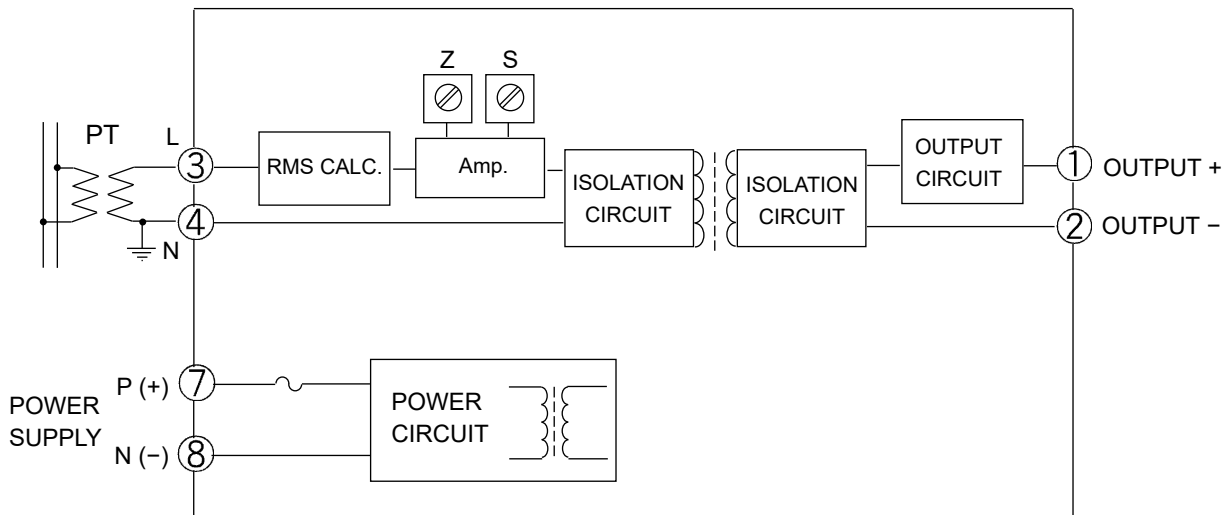

Ranges Available

	Current Signal	Voltage Signal
Output Range (DC)	0 to 20mA	-10 to 10V
Output Span (DC)	4 to 20mA	10mV to 20V
Output Bias	0 to 100%	-100 to 100%

* For current output signals, the accuracy of any current output smaller than 0.1mA is not guaranteed.
 Output Spec. Ex. 1: For 4 to 20mA output, the output span is 16mA and the bias +25%.
 Output Spec. Ex. 2: For -1 to 4V output, the output span is 5V and the bias -20%.

PERFORMANCE

Accuracy Rating	Better than ±0.1% of span (at 25°C±5°C).
Temperature Effect	Better than ±0.2% of span per 10°C change in ambient.
Response Time	
Voltage Output	80µs max. (0 to 90%) with a step input at 100%. (Frequency characteristics: 10kHz-3dB)
Current Output	150µs max. (0 to 90%) with a step input at 100%. (Frequency characteristics: 3kHz-3dB)
CMRR	100dB min. (500V AC, 50/60Hz)
Isolation	3-way isolation between input, output, and power.
Insulation Resistance	100MΩ min. (@ 500V DC) between input, output, and power.
Dielectric Strength	Input / Output / Power: 2000V AC for 1 minute (Cutoff current: 0.5mA)
Surge Withstand Capability	Tested as per ANSI/IEEE C37.90.1-1989.
Operating Environment	Ambient temperature: -5 to 55°C Humidity: 5 to 90% RH (non-condensing)
Storage Temperature	-10 to 60°C

PHYSICAL

Installation	Wall/DIN rail mounting
Mounting Direction	Vertical
Screwing Torque	0.78 to 1.18 [Nm] * Recommended
Wiring	M3.5 screw terminal connection
External Dimensions	W51 × H85 × D136.5 mm (including the socket)
Weight	Main unit: 200g max. Socket: 60g max.

MATERIAL

Housing	ABS resin (UL 94V-0)
Socket	ABS resin (UL 94V-0)
Screw Terminal	Galvanized steel with trivalent chromate finish
Printed Circuit Board	Glass fabric, epoxy resin (FR-4: UL 94V-0)

TERMINAL ASSIGNMENTS

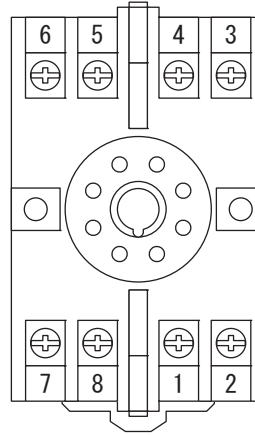

①	+ OUTPUT	
②	- OUTPUT	
③	+ INPUT	
④	- INPUT	
⑤	N.C.	
⑥	N.C.	
⑦	P (+)	POWER
⑧	N (-)	

BLOCK DIAGRAM

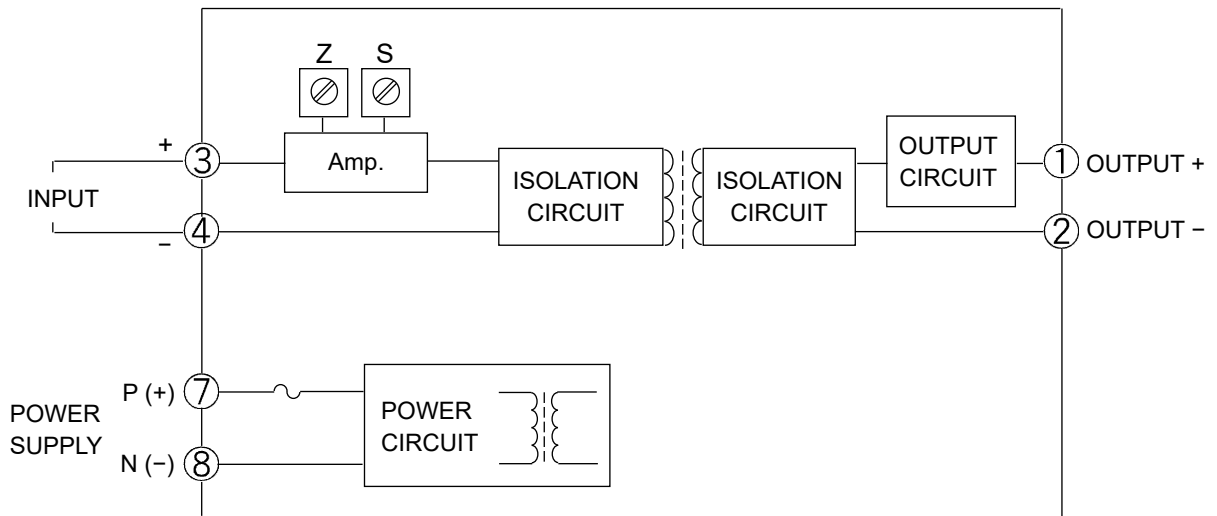

DESCRIPTION

The MS5544 is a plug-in high-level signal conditioner that converts DC current or voltage signals into commonly used DC signals and provides an isolated single output. This model features fast response.

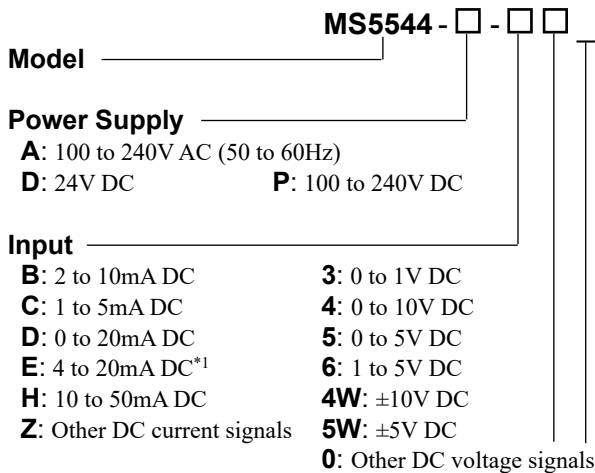
ORDERING CODE

*1: Shunt resistor 50Ω

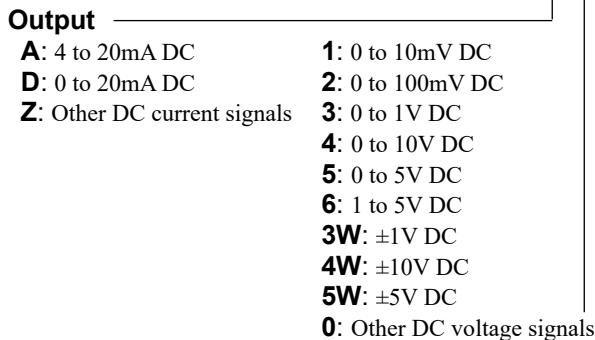

No code: None
/H: Polyurethane conformal coating
/X: Others (Special order)
 * For non-standard options, ask MTT for availability.

ORDERING INFORMATION

To place an order, please use the ordering code format as shown above.
 (e.g.) MS5544-A-4W4W

Other Ordering Examples:
 For an input code of "0": MS5544-A-06 (Input: 0.2 to 1V)
 For an output code of "0": MS5544-A-A0 (Output: 2 to 5V)
 For an option code of "X": MS5544-A-66/X (Response frequency: 5kHz)

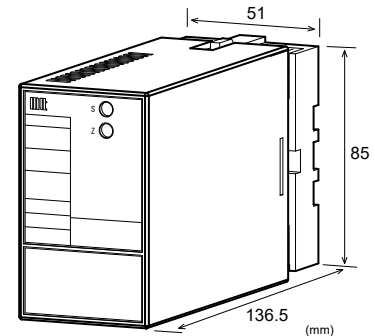
SPECIFICATIONS
POWER SECTION

Power Requirement	100 to 240V AC: 85 to 264V AC (47 to 63Hz) 24V DC: 24V DC±10% 100 to 240V DC: 85 to 264V DC		
Power Sensitivity	Better than ±0.1% of span for each power supply range.		
Power Line Fuse	160mA fuse		
Maximum Power Consumption			
Power	100-240V AC	24V DC	100-240V DC
	Approx. 4.0VA	Approx. 1.2W	Approx. 4.8W

INPUT SECTION

Input Resistance		
Voltage Input (DC)	1MΩ min. with or without power.	
Current Input (DC)	4 to 20mA (std.)	50Ω
	2 to 10mA	250Ω
	1 to 5 mA	100Ω
	0 to 20mA	50Ω
	10 to 50mA	10Ω
Allowable Input Voltage		
Voltage Input Model	30V DC max., continuous. (Standard for a span up to 10V)	
Current Input Model	40mA DC max., continuous. (Standard for 4 to 20mA)	

Ranges Available		
	Current Signal	Voltage Signal
Input Range (DC)	-100 to 100mA	-300 to 300V
Input Span (DC)	100μA*1 to 200mA	200mV*2 to 600V
Input Bias	-100 to 100%	-100 to 100%

Note: For any input range including negative input signals, the input spans for current and voltage signals range from (*1)200μA to 200mA and (*2)400mV to 600V, respectively.

Input Spec. Ex. 1: For 3 to 8V input, the input span is 5V and the bias +60%.

Input Spec. Ex. 2: For -5 to 0V input, the input span is 5V and the bias -100%.

● **OUTPUT SECTION**

Allowable Output Load		
Voltage Output (DC)	1V span and up	2mA max.
	10mV	10kΩ min.
	100mV	100kΩ min.
Current Output (DC)	4 to 20mA	750Ω max.
Zero Adjustment	Approx. ±5% of span. (Adjustable by the front-accessible trimmer.)	
Span Adjustment	Approx. ±5% of span. (Adjustable by the front-accessible trimmer.)	
Ranges Available		
	Current Signal	Voltage Signal
Output Range (DC)	0 to 20mA	-10 to 10V
Output Span (DC)	4 to 20mA	10mV to 20V
Output Bias	0 to 100%	-100 to 100%
* For current output signals, the accuracy of any current output smaller than 0.1mA is not guaranteed.		
Output Spec. Ex. 1: For 4 to 20mA output, the output span is 16mA and the bias +25%.		
Output Spec. Ex. 2: For -1 to 4V output, the output span is 5V and the bias -20%.		

● **PERFORMANCE**

Accuracy Rating	Better than ±0.1% of span (at 25°C±5°C).
Temperature Effect	Better than ±0.2% of span per 10°C change in ambient.
Response Time	
Voltage Output	80μs max. (0 to 90%) with a step input at 100%. (Frequency characteristics: 10kHz-3dB)
Current Output	150μs max. (0 to 90%) with a step input at 100%. (Frequency characteristics: 3kHz-3dB)
CMRR	100dB min. (500V AC, 50/60Hz)
Isolation	3-way isolation between input, output, and power.
Insulation Resistance	100MΩ min. (@ 500V DC) between input, output, and power.
Dielectric Strength	Input / Output / Power: 2000V AC for 1 minute (Cutoff current: 0.5mA)
Surge Withstand Capability	Tested as per ANSI/IEEE C37.90.1-1989.
Operating Environment	Ambient temperature: -5 to 55°C Humidity: 5 to 90% RH (non-condensing)
Storage Temperature	-10 to 60°C

● **PHYSICAL**

Installation	Wall/DIN rail mounting
Mounting Direction	Vertical
Screwing Torque	0.78 to 1.18 [Nm] * Recommended
Wiring	M3.5 screw terminal connection
External Dimensions	W51 × H85 × D136.5 mm (including the socket)
Weight	Main unit: 200g max. Socket: 60g max.

● **MATERIAL**

Housing	ABS resin (UL 94V-0)
Socket	ABS resin (UL 94V-0)
Screw Terminal	Galvanized steel with trivalent chromate finish
Printed Circuit Board	Glass fabric, epoxy resin (FR-4: UL 94V-0)

TERMINAL ASSIGNMENTS

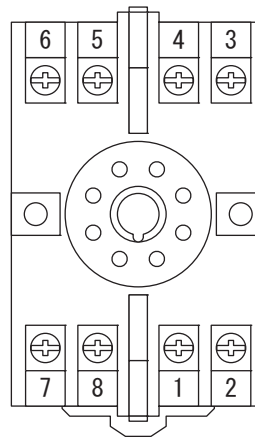

①	+ OUTPUT	
②	- OUTPUT	
③	+ INPUT	
④	- INPUT	
⑤	N.C.	
⑥	N.C.	
⑦	P (+)	POWER
⑧	N (-)	

BLOCK DIAGRAM

